



ASN Safety Bulletin #28

Frontal Head Restraint (FHR) devices are designed to restrain the driver's head relative to his torso during a frontal or angled-frontal impact, thereby reducing the loads on the neck.



FIA-approved FHR systems ([Technical List no. 29](#)) must be worn by drivers and co-drivers competing in competitions registered on the FIA Calendar as defined in Article 3 “Frontal Head Restraint (FHR)” of Chapter III “Drivers’ Equipment” to the International Sporting Code (ISC).

In order for the FHR to work effectively, it is important that it is installed in accordance with the “Guide and installation specification for HANS®, Hybrid and Hybrid Pro devices in racing competition”. ASN Safety Bulletins [Nos 14](#) and [15](#) provide the best practices for selecting and installing the devices.

In addition, it is fundamental that the FHR, FHR tether, helmet and Helmet-M6-Terminal are FIA approved. As there are different standards for helmets, Helmet-M6-Terminals, FHR tethers and FHR devices, it is important to ensure that the compatibility amongst these parts respect Article 3.3 “Compatibility and permitted use of items approved to the FIA 8858-2002, 8858-2010, 8859-

2015, 8860-2010 and 8860-2018 standards” of Chapter III “Drivers’ Equipment” to the ISC. Compatibility and permitted use of items approved under FIA Standards 8858-2002, 8858-2010, 8859-2015, 8860-2010 and 8860-2018.

FHR systems must only be worn with FIA-approved items according to the following charts:

Compatibility between FHR tethers and FHR

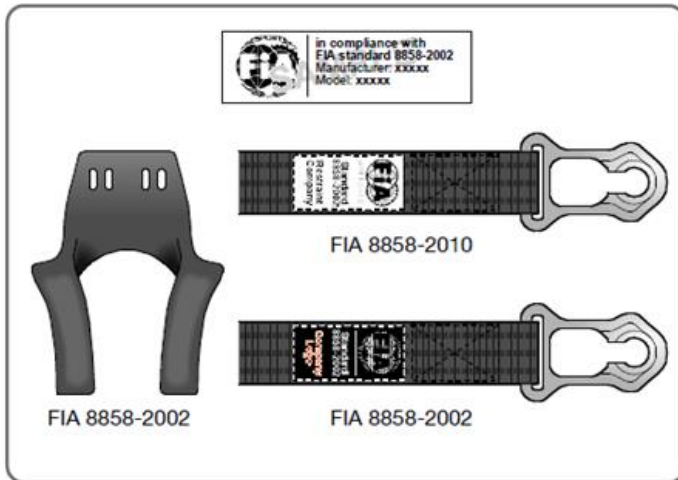

8858-2002 FHR – can be used with FIA-approved 8858-2002 and 8858-2010 FHR tethers (Technical List no. [29](#))

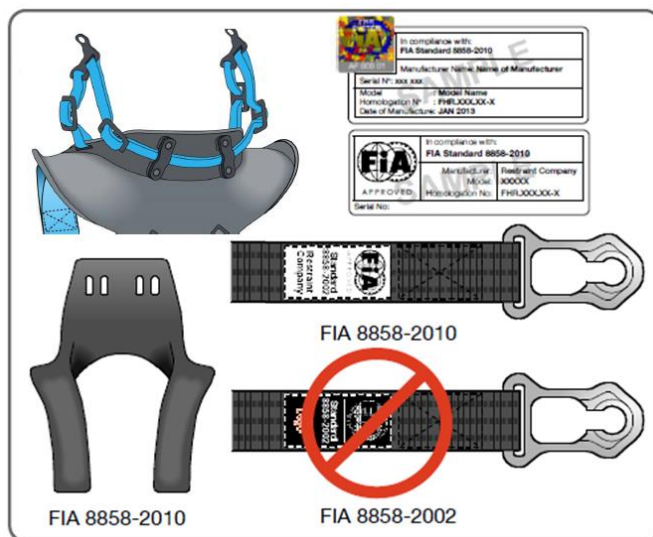

8858-2010 FHR – can only be used with FIA-approved 8858-2010 FHR tethers (Technical List no. [29](#))

Compatibility between helmet and Helmet-M6-anchorage



8858-2002 Helmet-M6-anchorage – can only be used with FIA-approved 8858-2002 helmets (Technical List no. [41 – Part 2](#))

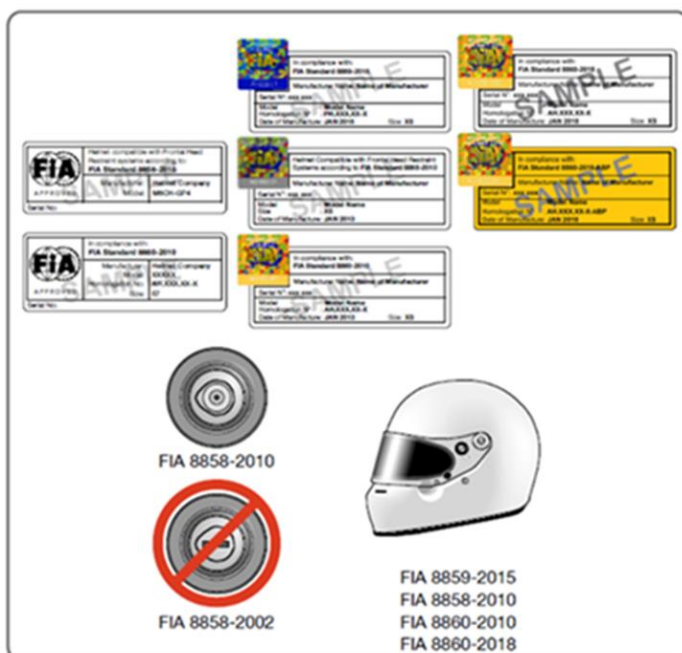

8858-2010 Helmet-M6-anchorage – can be used with FIA-approved 8858-2010, 8859-2015, 8860-2010 and 8860-2018 helmets (Technical List nos [41-Part 1](#), [33](#), [49](#) and [69](#))

Any of the below combinations are acceptable as they respect the requirements that:

- the compatibility between the tethers and the FHR itself, as well as between the M6-Anchorage and the Helmet itself is confirmed, and
- between the tether end-fitting and Helmet-M6-anchorage there is the correct mechanical compatibility (i.e. the devices can be correctly attached).

Combination 1

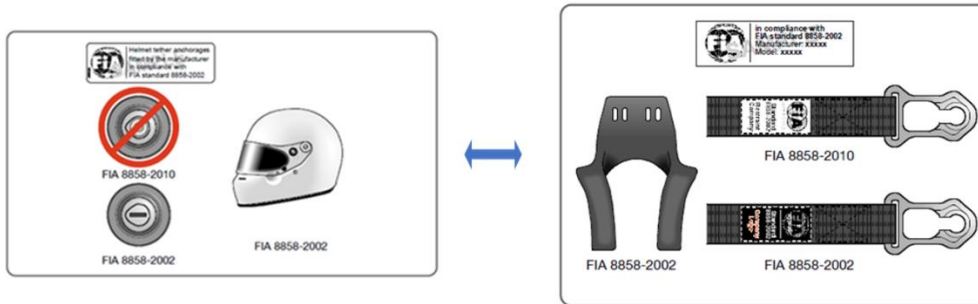

Combination 2

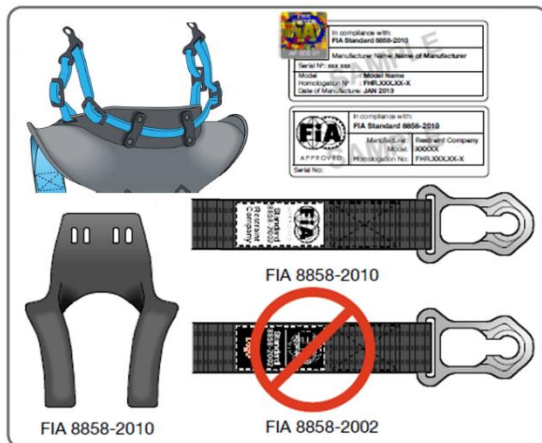

Combination 3

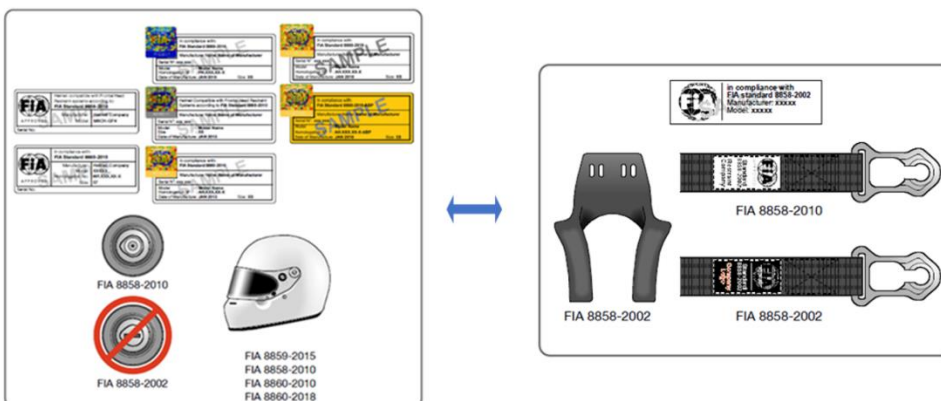

Combination 4

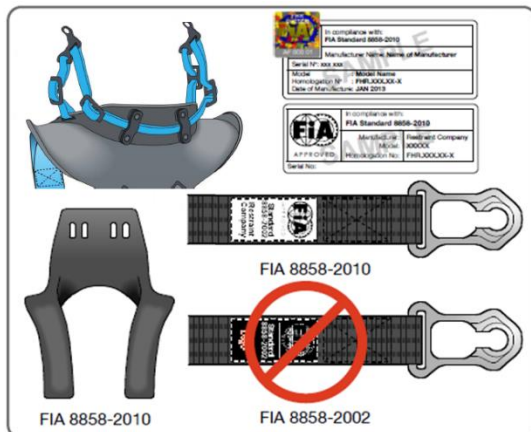

We would like to remind competitors participating in competitions registered on the FIA Calendar that helmets in compliance with FIA Standards 8858-2002 and 8858-2010 (Technical List No. [41](#)) will be accepted until 31.12.2023.

FIA Safety Department